

REVISIONS

NO | DATE | REVISION | BY

1 19/09/12 ISSUED FOR BP/TENDER JG

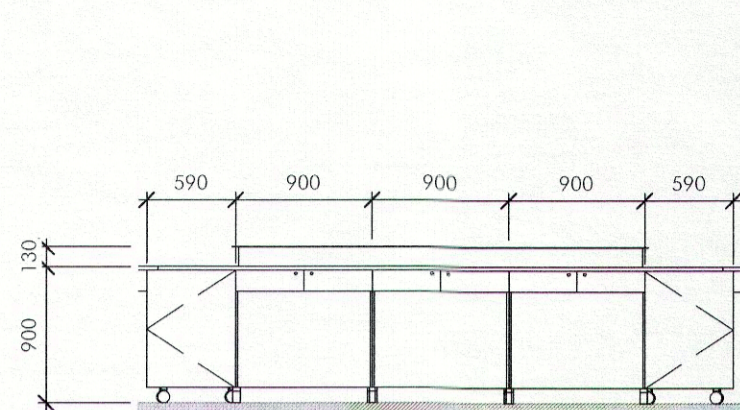

4 COUNCIL FRONT 2
A2.02 1:50



3 COUNCIL FRONT 1
A2.02 1:50

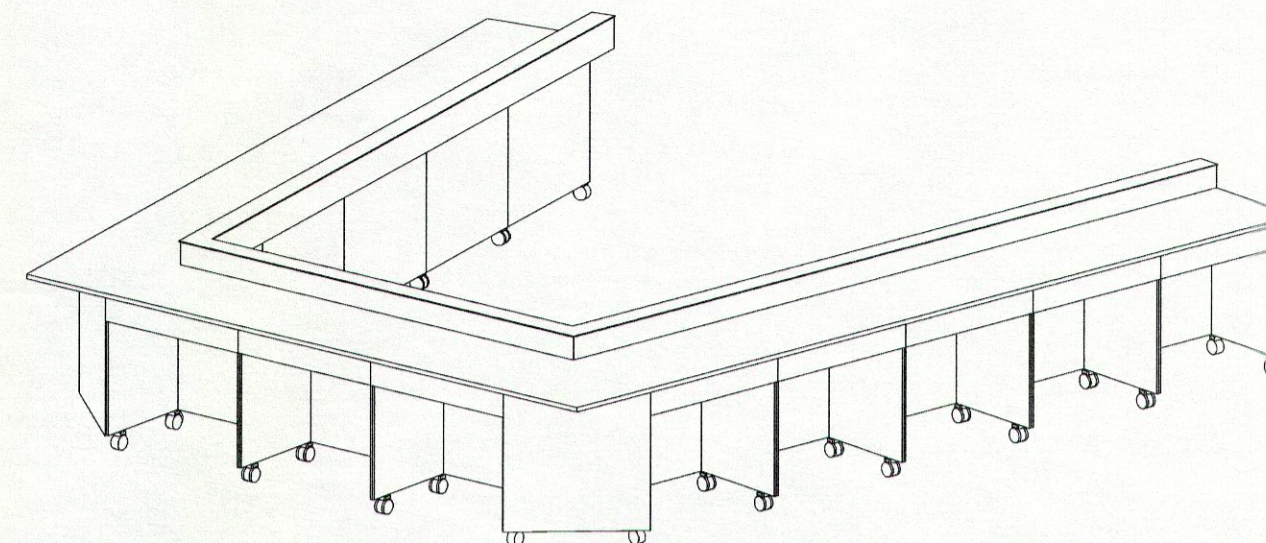

1 COUNCIL DESK - 3D



6 COUNCIL BACK 2
A2.02 1:50

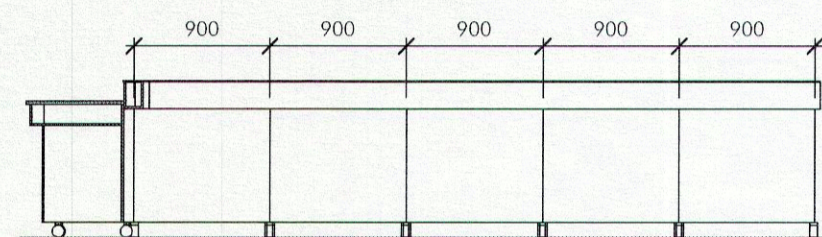

5 COUNCIL BACK 1
A2.02 1:50

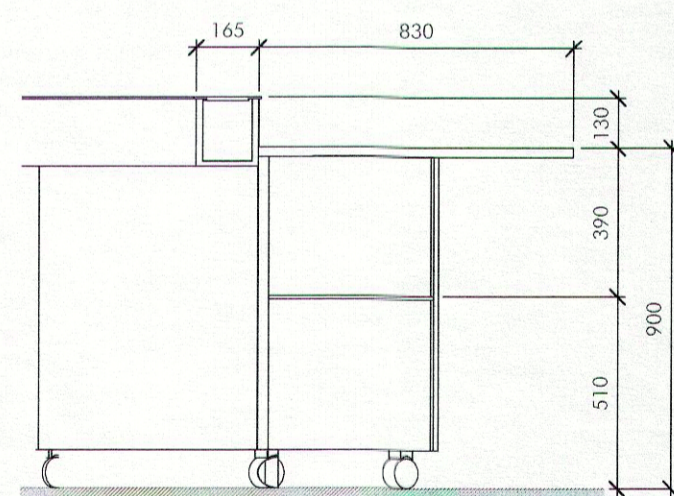

8 COUNCIL DESK SECTION 2
A8.03 1:20

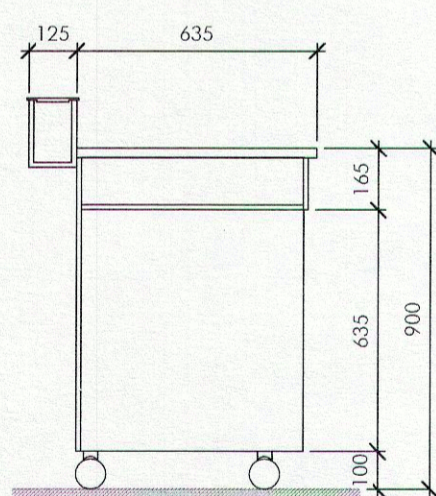

7 COUNCIL DESK SECTION 1
A8.03 1:20

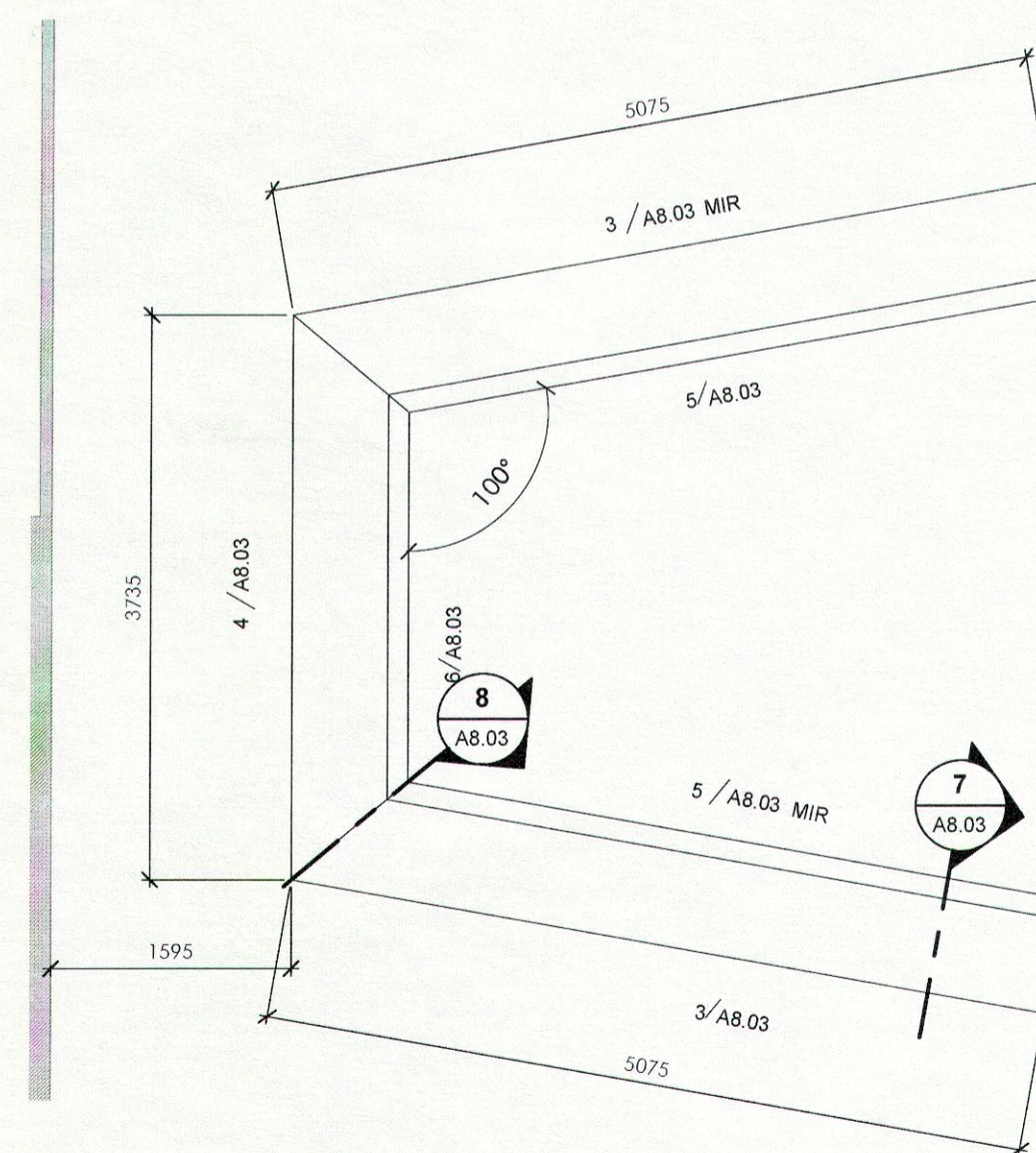

2 COUNCIL DESK - FLOOR PLAN
A3.01 1:50

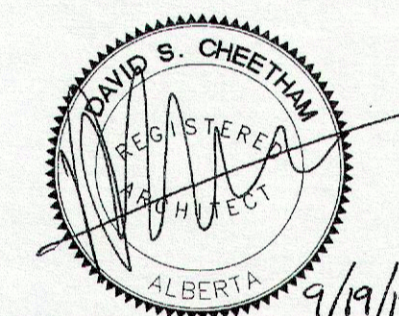

Group2 Architecture Interior Design Ltd., Red Deer
PERMIT No. AC 552
ISSUED PURSUANT TO THE
ARCHITECTS ACT OF ALBERTA

Group2
architecture
interior design

Group2 Architecture Interior Design Ltd.
www.group2.ca E: general@group2.ca Copyright © 2012
Red Deer T: 403.340.2200 Calgary T: 403.717.2511
Edmonton T: 780.447.2990 Saskatoon T: 306.979.2935

PROJECT TITLE
**DRUMHELLER TOWN
HALL RELOCATION**

DRAWING TITLE
COUNCIL CHAMBERS DESK

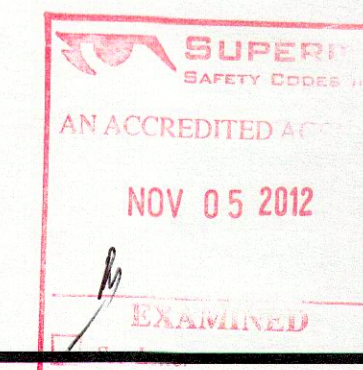

NO	DATE	REVISION	BY
JG	RO	09/18/12	
12034	A8.03	1	
FILE	DRAWING	REVISION	